

wired for innovation

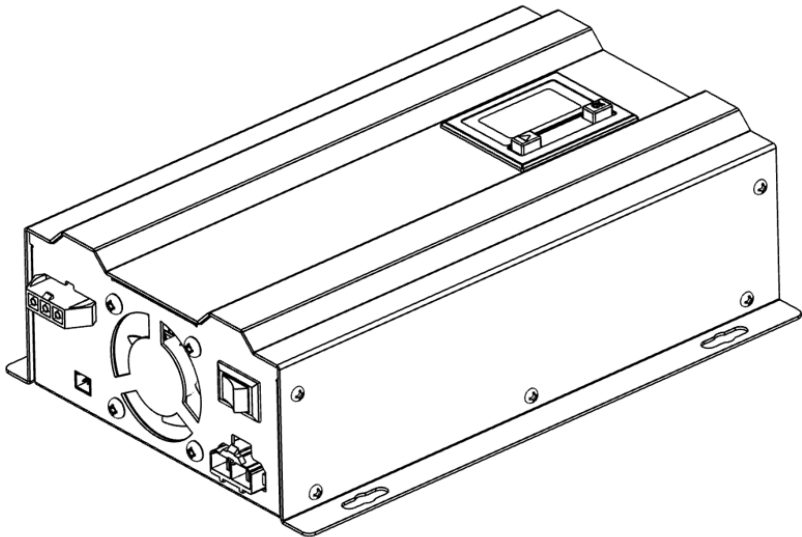

# AC-DC Battery Charger Installation & User Instructions

PX310

# Contents

<b>Overview .....</b>	<b>2</b>
Key Features.....	2
Display .....	3
<b>Installation &amp; Setup .....</b>	<b>3</b>
Safety warnings.....	3
Wiring & Fusing.....	4
DC Connections.....	4
AC Connections.....	4
Mains On Connection .....	5
Battery Type Selection.....	5
Charging Stages .....	5
<b>Operation .....</b>	<b>6</b>
Display Information .....	6
Fan Operation .....	7
Power Supply Mode .....	7
Wakeup Mode .....	8
Error Modes .....	8
<b>Specification .....</b>	<b>9</b>

# Overview

The PX310 multi-stage battery charger is designed for leisure vehicle applications, providing power for both battery charging and 12 volt appliances. The integrated LCD display shows battery charging status and allows setup for different battery chemistries. A PSU mode allows the charger to be used without a battery fitted and the Silent mode avoids noise during overnight charging.

## Key Features

- Selectable charging for Flooded, AGM, Gel & LiFePO<sub>4</sub> batteries
- 3-Stage charging at up to 20 Amps for fast effective charging
- Integrated LCD display shows battery charging status
- Intelligent fan cooling with Silent Mode
- PSU Mode allows operation when no battery is fitted
- Protected against over load, over voltage, over temp & short circuit

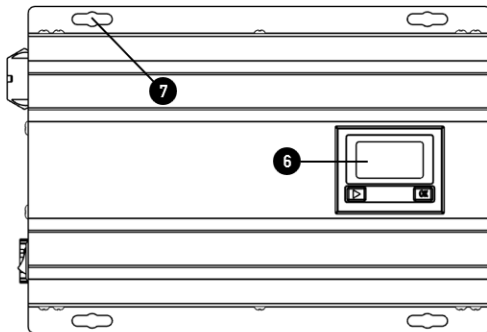
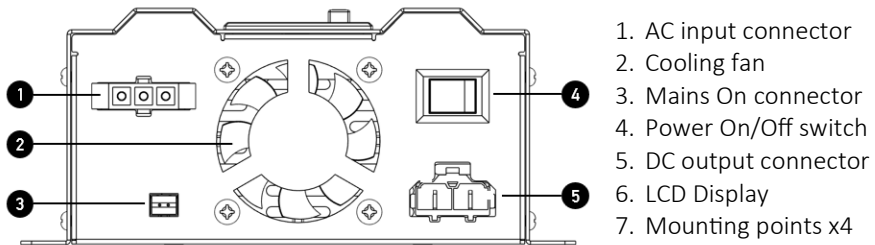

## Display



An LCD display shows useful information about the battery charging status and also allows the charger settings to be configured.

## Installation & Setup

The charger should be installed horizontally or vertically as close to the leisure battery as possible, ensuring the surrounding area is dust free and well ventilated. During operation the chargers cooling fan will exhaust warm air, so ensure there is at least 10cm clear around the charger at all times.

## Safety Warnings

- Explosive gases may be present near the battery when charging - prevent flames and sparks.
- Always provide adequate ventilation during charging
- Disconnect the supply before making or breaking the connections to the battery
- Be aware the charger surface may become hot under operation
- Do not use this charger with incompatible or non-rechargeable batteries
- Not to be used by children under 8 years old
- Only to be used by children after sufficient explanation it is not a toy and is not to be used to recharge non-rechargeable batteries
- Examine charger regularly and do not use until repaired if there is damage to the cord, plug or enclosure

## Wiring & Fusing

When fitting, try to keep cabling runs as short as possible and do not underrate, as this will lead to excessive voltage losses and reduced performance. Under full load the charger will draw a large amount of current, please refer to the table to select a suitable wiring gauge, length and recommended fuse rating.

Up to 3m	Up to 6m	Up to 10m	Fuse
4mm <sup>2</sup> 12AWG	6mm <sup>2</sup> 10AWG	10mm <sup>2</sup> 7AWG	30A

To aid fitting, the charger can be purchased as a kit (Part: PX310-KIT), which includes the mating cables, connectors and terminals, or alternatively these can be purchased directly from Sargent.

Description	Sargent Part	Molex Part	Qty
AC Connection cable (500mm)	51006-09	-	1
Receptacle Housing, 2-way	17114	428160212	1
Crimp Terminal, Female	17122	428150114	2

## DC Connections

When connected as shown, the battery charger can be used to charge the battery and also provide power to 12 volt leisure circuits. In this situation the available power will be shared between the leisure circuits and the battery, up to the maximum rating of 20Amps (300 watts)

## AC Connection

The AC input to the charger should be protected by an MCB or fuse rated no higher than 6Amps, as shown below.

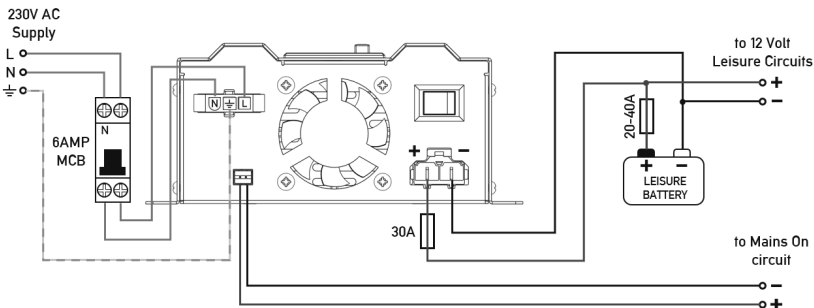

**IMPORTANT** - It is recommended to use a qualified electrician when installing mains equipment.

## Mains On Connection

This connector will supply a 12 volt output whenever there is a 230V mains supply to the charger and it is switched on. This is used by some Sargent control panels to indicate the mains supply is active. If this feature is not required it can be left disconnected.

## Battery Type Selection

Before using the charger, the correct battery type should be set from the LCD display using the following procedure,

1. After switching on charger press **OK** button for 3 seconds to enter Setup Mode, the battery type should then start to flash
2. Press **▶** button to change battery type, then press **OK** to confirm

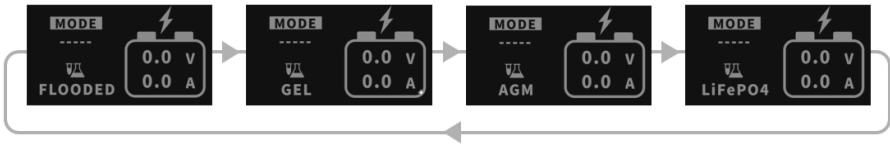

The table below shows the charging voltages used for each battery type.

Battery Type	Flooded	Gel	AGM	LiFePO4	PSU
Boost charge	14.5V	14.1V	14.7V	14.6V	-
Float charge	13.4V	13.6V	13.6V	13.8V	13.6V

## Charging Stages

Depending on the battery type selected, the 3-stage charging profile will be adjusted to maximise charging performance.

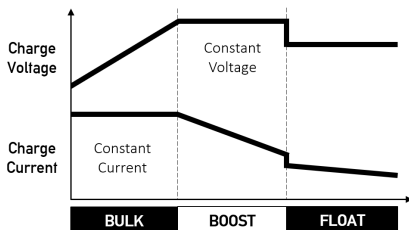

- BULK** The battery is charged with maximum current, whilst the voltage climbs steadily, until the boost voltage setting is reached.
- BOOST** The battery voltage is held constant while the current gradually decreases, until the battery is becoming full.
- FLOAT** The voltage of the battery will reduce to the float voltage setting and current will reduce to a trickle charge to help offset any self-discharge.





Once the charging cycle is complete, the charger will remain in the Float Mode until the mains supply is removed and re-connected or the power switch is cycled off then on again.

## Operation

After applying mains power and moving the power on/off switch to the On position, the operation is totally automatic and can be left on continuously as required.

## Display Information

During charging, the display will show useful information about the charging status

Display	Description
	The current charging mode, which will advance from BULK > BOOST > FLOAT as the battery charges
	The currently selected battery chemistry, which can be Flooded, Gel, AGM or LiFePO4
	The battery charging Voltage and Current
	This symbol shows if the cooling fan is in Normal or Silent Mode

## Fan Operation

The unit is fitted with an intelligent cooling fan, which can adjust its speed depending on the load and temperature, as shown in the following table.

Load	Internal Temp	Fan Speed
0 - 5A	< 70°C	OFF
5 - 20A	< 70°C	0 - 50%
	70 - 110°C	75% - 100%
	> 110°C	Thermal Shutdown

In order to restrict noise (for example at night) the fan can be put into Silent Mode. In this mode the fan will always be off but the charger output will be restricted to a maximum of 5amps.

1. During charging press the ► button for 3 secs to enter Silent Mode
2. Press the button again to exit Silent Mode

The charger will also exit the Silent Mode when:-

- i) The charger is turned off then on again
- ii) 12 hours have passed

## Power Supply Mode

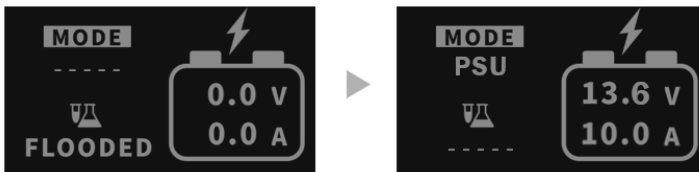

After the charger is switched on, it will check if a battery is connected. If no battery is detected, the charger will enter PSU Mode and output a constant 13.6 volts. This enables the charger to be used as a power supply when no battery is fitted.

If a battery is detected it will enter the normal 3-stage charging cycle.



## Wakeup Mode

If battery type LiFePO4 has been selected, then during startup the charger will briefly enter Wakeup Mode in order to wake a sleeping lithium battery. This will help avoid the charger entering PSU Mode due to no battery being detected.

## Error Modes

If there is a problem during charging, the display will show a warning message and disable the charger output

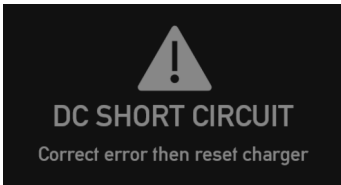

Fault	Solution	Action taken
DC SHORT CIRCUIT	Check if charger DC output has a short circuit	Output disabled. Warning is displayed until charger is power cycled.
DC OVER CURRENT	Check output load does not exceed chargers maximum rating	Output disabled. Warning is displayed until charger is power cycled.
DC OVER VOLTAGE	Check an incompatible battery has not been connected e.g. 24V rather than 12V	Output disabled. Warning automatically resets when problem is removed.
OVER TEMPERATURE	Check the charger fan is working and that venting slots are covered	Output disabled. Warning automatically resets when problem is removed.
DC REVERSE POLARITY	Check if the DC output terminals have been reversed	Output disabled. Warning automatically resets when problem is removed.
AC OVER VOLTAGE	Check if the charger AC input voltage is too high	Output disabled. Warning automatically resets when problem is removed.
AC UNDER VOLTAGE	Check if the charger AC input voltage is too low	Output disabled. Warning automatically resets when problem is removed.

# Specification

<b>Model</b>	<b>PX310</b>
Power	300W
Input Voltage	200 - 240VAC
Charging Current (max)	20A @14.5V
Boost Voltage	14.7V (max)
Float Voltage	13.8V (max)
Compatible batteries	Flooded, Gel, AGM, Lithium
Recommended battery size	70 - 220Ah
Cooling method	Intelligent fan with Silent Mode
Dimensions	221 x 157 x 67mm
Weight	1.54kg

# Notes



**Sargent Electrical Services Ltd**

Unit 39, Tokenspire Business Park, Beverley, East Yorks, HU17 0TB, UK

Phone: +44(0)1482 881655 | Fax: +44(0)1482 678987

Email: [support@sargentltd.co.uk](mailto:support@sargentltd.co.uk)

Tech Support: +44(0)1482 678981



**H011**